

FEATURED ALUM-A-LIFT CLEANROOM HANDLING SYSTEM FOR QUARTZ GLASSWARE

PROJECT 30235



MODEL A800CRCS-72

FEATURING Dual Booms w/ Four Hooks, Low-Profile Base Configuration, Quick Exchange Batteries

HANDLING 300 lb [136 kg] Baskets

DETAILS Semiconductor manufacturing processes often involve the use of quartz glassware. Configured for use in a Class 100 (ISO 5) cleanroom, this Alum-a-Lift is used to transport baskets full of quartz parts between a chemical cleaning tank and a rinsing tank. Booms and hooks designed specifically to fit the dimensions of the basket ensure safe and reliable handling of the fragile quartz parts. With a small clearance at the underside of the tanks, a low-profile base configuration allows the lift to be lightweight and maintain a small footprint, which is often critical in cleanroom applications.

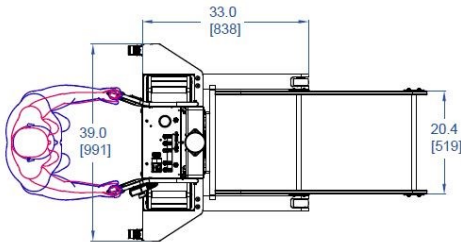

****SUITABLE FOR USE IN CLASS 100 CLEANROOM****

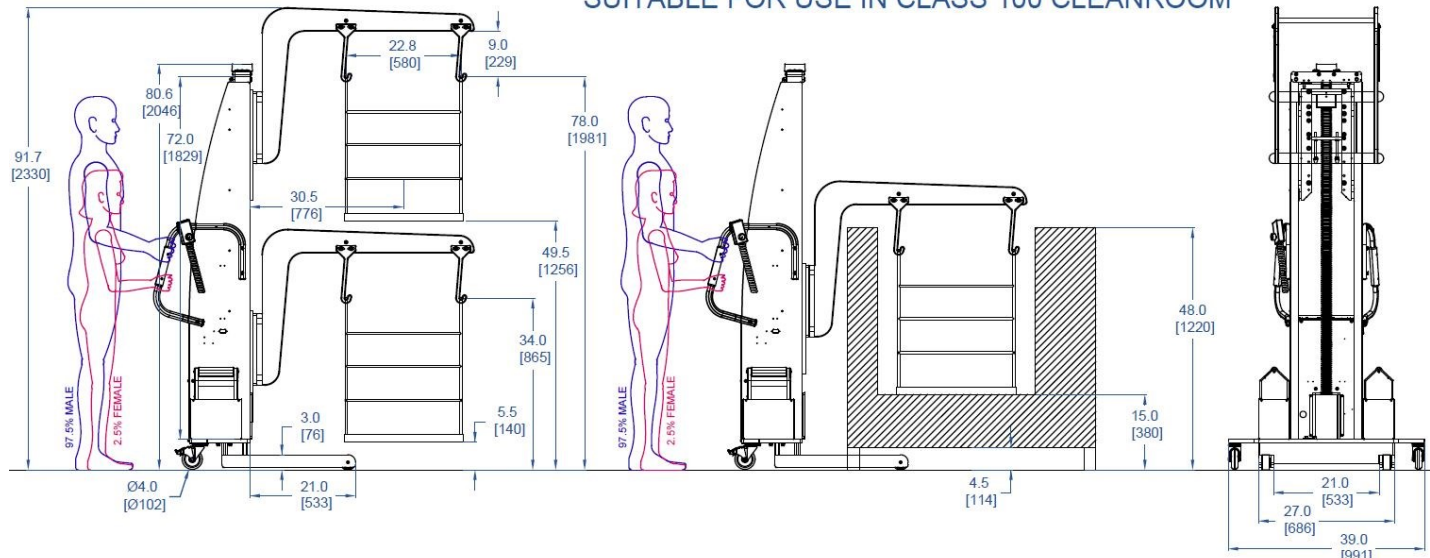

alum-a-lift

13941 Veterans Memorial Hwy
Winston, GA 30187 USA
+1 770 489 0328

GET STARTED AT ALUM-A-LIFT.COM